



## Main Features:-

- ◆ Screwed BSPP
- ◆ Temperature -10°C to 110°C.
- ◆ Fixed Stainless Steel Filter
- ◆ Rated PN16 ½" to 1", PN10 1¼" to 2", PN8 2½" to 4"

\*Temperature and pressure determined by valve body, seat etc.

## Suitable Applications & Approvals:



INDUSTRY

## SERIES: 30023

MANUFACTURER: **AVOL**  
INDUSTRIAL VALVES



No	Name	Materials
1	Body	Brass
2	Disc	POM
3	Washers	NBR
4	Spring	AISI 302
5	Filter Fittings	Nylon
6	Filter	AISI 304L

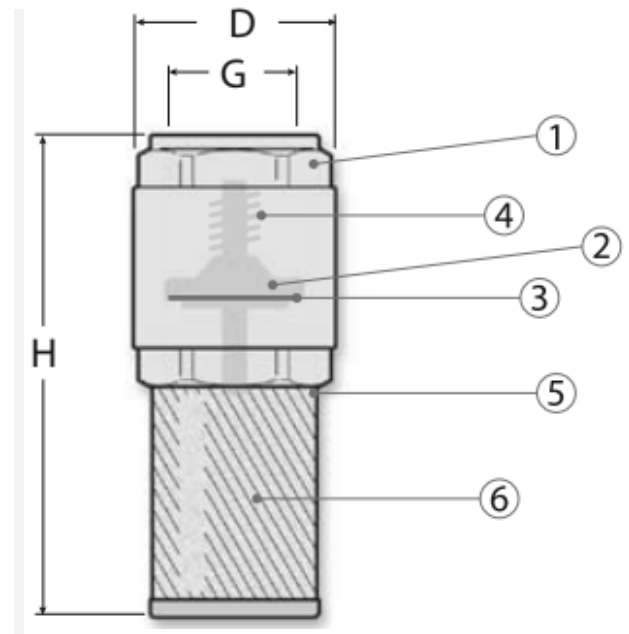

VALVE DIMENSIONS

G	D	H	Kg
1/2"	29	80	0.11
3/4"	37	90	0.12
1"	44	100	0.18
1 1/4"	56	110	0.27
1 1/2"	63	126	0.33
2"	78	146	0.56
2 1/2"	103	162	1.05
3"	120	188	1.6
4"	155	214	2.58

## Mesh Details

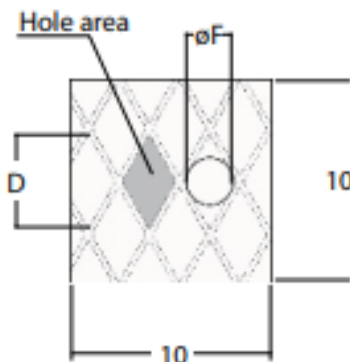

Size	1/2" to 1 1/2"	2" to 4"
∅F	1mm	1.25mm
D	2mm	2.6mm
Hole Area	1mm <sup>2</sup>	1.7mm <sup>2</sup>
Holes/cm <sup>2</sup>	30	13

T +44 (0)1386 552369

E sales@allvalves.co.uk

W www.allvalves.co.uk

F +44 (0)1386 554227

